

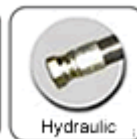

Universal 4" Mixer Model M4-G

Surface to Surface Inc.

Features and Benefits M4-G Mixer



The M4-G universal mixer is designed around the time proven M series mixers of STS. Powered by an 18 hp air-cooled gasoline engine driving a 4" centrifugal pump, it makes effective use of the patented 4 point mixing system. The M4-G can be used as a new installation or retrofitted into an existing system of tank(s). Since the unit is connected by hose and not hard pipe, the placement of the mixer versus the tank(s) is less restricted and a configuration to suit the needs of the contractor are easier to achieve. The small size also makes it a portable, independent unit that is easier to transport from site to site.

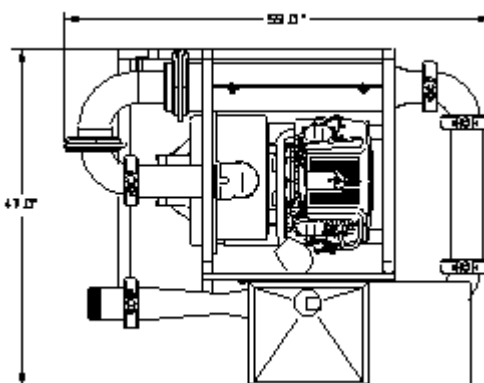

Photo: **Not exactly as shown**
M3G (3") Model Shown

Specifications

- Dimensions
- Weight
- Hopper Height
- Mixing System
- Flow Valves
- Skid Frame
- Engine
- Pump
- Pump Coupling
- Vacuum Port
- Pipe Couplers
- Pressure Wand
- Internal Jet Guns

M4-G Mixer

- 47" W x 59" L x 35 1/2" H
- 720 Lbs
- 35-1/2" High
- 4" Patented StS Mixing System
- Brass and Steel construction
- 1 1/2" steel tube with fork pockets
- 18 hp air-cooled, manual start
- 4" Cast iron centrifugal trash pump
- Direct coupled engine & pump
- 1 1/2" NPT Inlet
- Bolt & Snap-groove type
- Hopper maintenance wand
- TurboMix™ Eductor Nozzles

Benefits

- Small space saving footprint.
- Light weight for easy transportation.
- Waist high hopper reduces back strain.
- Fast & efficient with high shearing ability.
- Withstand the abuse of daily operations
- Built tough for the construction trade.
- Industrial rated for longer service life.
- Rugged & repairable for extended service life.
- No expensive couplers or inserts to replace.
- Draw Fluid into system without additional pump.
- Fast cold weather draining of system.
- Removal of blockages caused by additive.
- Fast and effective rolling and mixing action.

Also available in Electric (M4-E) or Hydraulic (M4-H) models.

*** All Specifications Subject to Change Without Notice ***

Check our website for the latest products and specifications
www.stswm.com info@stswm.com

Surface to Surface Inc.

5150 Forest Road, R.R.#3, Watford, Ontario, N0M 2S0
Tel: 1-800-567-0978

04/16/07